



MULTIBOX
Carton forming machine



SACMI

MULTIBOX

Macchina automatica idonea alla formazione di cartoni di tipo americano, con chiusura delle falde inferiori per mezzo colla a caldo HOT MELT

Automatic machine suitable for forming American style cartons. Lower flaps are closed by means of HOT MELT glue

Automatische Maschine für die Aufrichtung von Kartontrays des amerikanischen Faltschachteltyps, mit Schließung der unteren Laschen mittels Heißklebstoff HOT MELT.

Máquina automática adecuada para la formación de cartones de tipo americano, con cierre de las solapas inferiores mediante cola en caliente HOT MELT

Machine automatique adaptée pour la formation de cartons de type caisse américaine, avec fermeture des rabats inférieurs au moyen de colle à chaud HOT MELT.

Dati tecnici / Specifications / Technische Daten / Datos Técnicos / Données techniques	
Produzione oraria / Hourly production / Stundenproduktion / Producción por hora para la maquina standard / Production horaire	Max 1000/800 cartoni/ora - cartons/hour - Kartons/Stunde - cartones/hora - cartons/heure il ritmo di produzione dipende dal formato e dalle dimensioni della scatola depending on the format shape and dimensions /aber der Produktionsrhythmus hängt vom Format und von den Abmessungen des Kartons ab / cartones/hora dependiente de la forma de la cajas y las medidas / production dépendant du format et des dimensions de la boîte
Potenza installata / Installed power / Installierte Leistung / Potencia Instalada / Puissance installée	4 kw
Tensione rete / Supply voltage / Netzspannung / Tensión de red / Tension secteur	400 V/50Hz (trifase+neutro+terra) / (three-phase+neutral+ground) / (dreiphasig+neutral+Erde) / (trifase+neutro+tierra) / (triphase+neutre +terre)
Voltaggio ausiliari / Auxiliary voltage / Spannung Hilfsstromkreise / Voltaje auxiliares / Voltage équip. auxiliaires	24 V
Consumo aria / Air requirements / Luftverbrauch / Consumo aire / Consommation air	150 Nit/min
Pressione aria / Air pressure / Luftdruck / Presión aire / Pression air	6/8 bar
Senso di avanzamento / Direction of forward movement / Vorlaufrichtung / Sentido de avance / Sens d'avancement	lato corto del cartone / short side of the carton / kurze Seite des Kartons / lado corto del cartón / côté court du carton
Colore macchina / Machine color / Maschinenfarbe / Color máquina / Couleur machine	Ral 9006
Altezza macchina / Machine height / Maschinenhöhe / Altura máquina / Hauteur machine	2.000 mm
Altezza uscita cartoni / Carton outfeed height / Höhe Kartonauslauf / Altura salida cartones / Hauteur sortie cartons	650 mm regolabile (+- 50 mm da terra) / adjustable (+- 50 mm from the ground) / verstellbar (+/- 50 mm vom Boden)/ regulable (+- 50 mm desde tierra) / réglable (+- 50 mm du sol)
Peso macchina / Machine weight / Maschinengewicht / Peso máquina / Poids machine	1500 kg
Capacità magazzino cartoni / Carton magazine capacity / Fassungsvermögen Kartonmagazin/ Capacidad almacén cartones / Capacité magasin cartons	180 pezzi (a seconda dello spessore) / pieces (according to thickness) / Teile (je nach Dicke) / piezas (en función del espesor) / pièces (en fonction de l'épaisseur)
Linguaggio display / Display language / Displaysprache / Idioma display / Langue afficheur	Italiano / English
N.01 Manuale di uso manutenzione / Use and maintenance manual / Bedienungs- und Wartungshandbuch / Manual de uso y mantenimiento / Manuel d'utilisation et maintenance	Italiano / English
N.01 schema elettrico / wiring diagram / Stromschaltplan / esquema eléctrico / schéma électrique	Italiano / English
N.01 schema pneumatico / pneumatic diagram / Druckluftschaltplan / esquema neumático / schéma pneumatique	Italiano / English
Min-max dimensioni cartone chiuso (mm) / Min.-max. dimensions for closed carton (mm) / Min.-max. Abmessungen geschlossener Karton (mm) / Min-máx dimensiones cartón cerrado (mm) / Dimensions min-max carton fermé (mm)	lunghezza / length / länge / longitud / longueur 200- 400 larghezza / width / breite / anchura / largeur 100 - 400 altezza / height / höhe / altura / hauteur 100 - 350

LIMITI MACCHINA STANDARD / LIMITS OF THE STANDARD MACHINE / STANDARDMÄSSIGE MASCHINENBESCHRÄNKUNGEN / LIMITE MAQUINA STANDARD / LIMITES MACHINE STANDARD

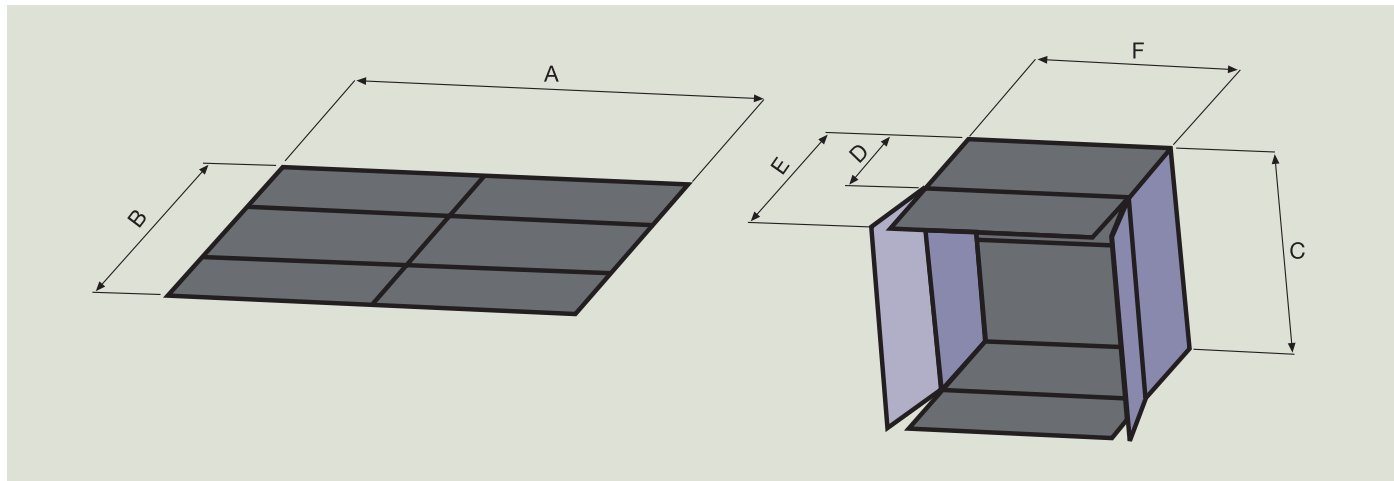

MULTIBOX	A	B	C	D	E	F
Min.	300	200	100	100	150	200
Max.	800	750	400	350	550	400

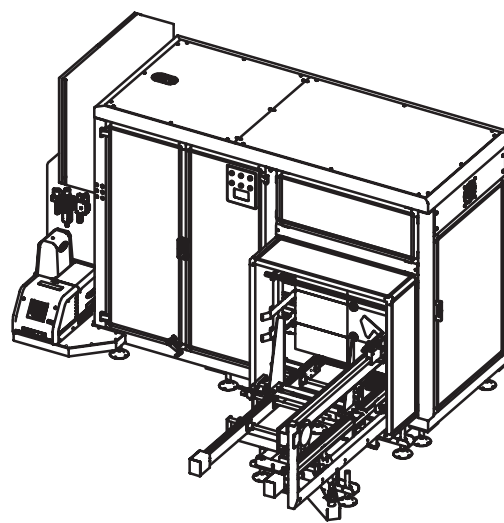
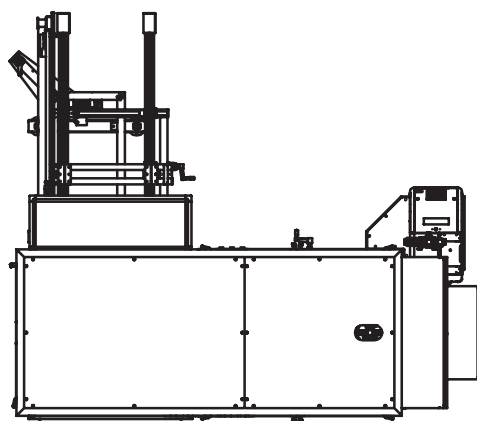
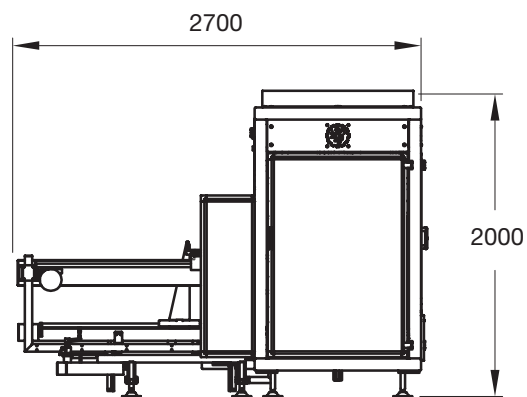
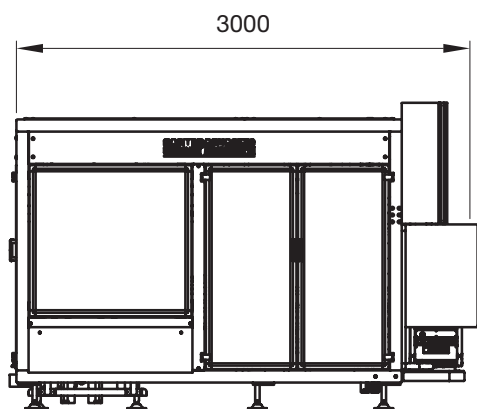



Sacmi Packaging S.p.A. Via Brodolini, 10/A - 40026 Imola (BO) Italy
Tel. +39 0542 649 811 - Fax. +39 0542 640 783
E-mail: inform@sacmipackaging.it
www.sacmipackaging.com