



SACMI

TF12 Evolution - TF12 Compact

TF12 Evoluzione

Automatic tray forming machine

Macchina automatica formatrice di vassoi
Automatische Steigenaufrichtmaschine
Máquina automática formadora de bandejas



- EN**
- High flexibility
 - Quick format changeover
 - High output capacity
 - Easy handling and accessibility
 - Low noise
 - High reliability
 - Minimum maintenance

- DE**
- Hohe Flexibilität
 - Schneller Formatwechsel
 - Hohe Produktivität
 - Einfache Bedienung und einfache Zugänglichkeit
 - Niedriger Geräuschpegel
 - Hohe Zuverlässigkeit
 - Geringe Wartung



TF12 Compact



- IT**
- Elevata flessibilità
 - Rapido cambio formato
 - Alta capacità produttiva
 - Facile conduzione e accessibilità
 - Bassa rumorosità
 - Elevata affidabilità
 - Minima manutenzione

- ES**
- Elevada flexibilidad
 - Rápido cambio de formato
 - Alta capacidad de producción
 - Fácil conducción y accesibilidad
 - Bajo nivel de ruido
 - Elevada fiabilidad
 - Mantenimiento mínimo



Working cycle

Ciclo di lavoro
Betriebszyklus
Ciclo de trabajo

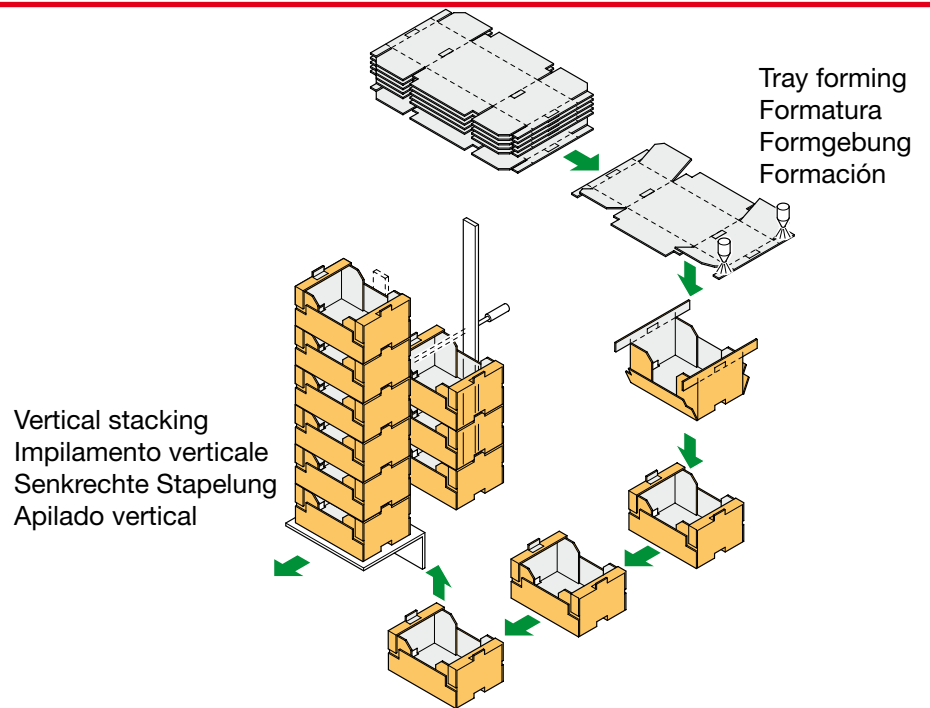

Central adjustment units for quick format changeover
 Regolazioni centralizzate per cambio formato rapido
 Zentralisierte Einstellungen für schnellen Formatwechsel
 Regulaciones centralizadas para cambio rápido de formato



Standard hopper
 Tramoggia standard
 Standardtrichter
 Tolva estándar



Touch-screen operator interface
 Pannello di controllo touch screen
 Berührungssensitiver Bildschirm
 Panel de control touch screen



Blank magazine
 Magazzino fustellati
 Zuschnittmagazin
 Almacén troquelados

Trays type

Tipologia di plateaux

Steigenausführungen

Tipología de plateaux

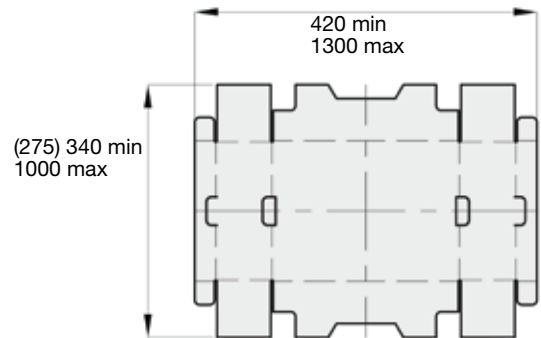
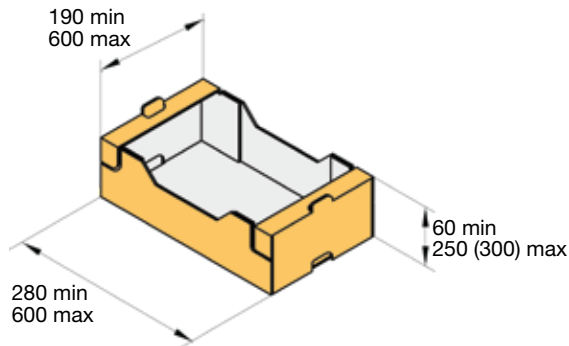

STANDARD PLAFORM / PLAFORM STANDARD / STANDARD PLAFORM / PLAFORM ESTÁNDAR

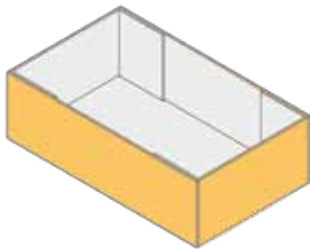

Simple tray
Vassoio semplice
Einfache Steige
Bandeja simple

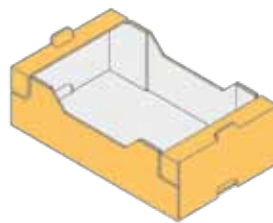

Standard top-flap tray
Vassoio standard con tettuccio
Standardsteige mit Decke
Bandeja estándar con tapa top-flap

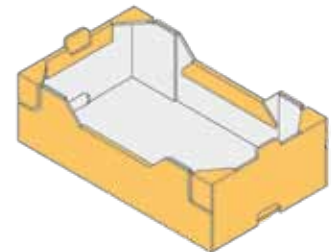

Tray with long and short side doubling
Vassoio con raddoppio testate e fiancate
Steige mit verdoppelten Kopfseiten und Seitenwänden
Bandeja con pared doble en la parte superior y laterales

CITRUS

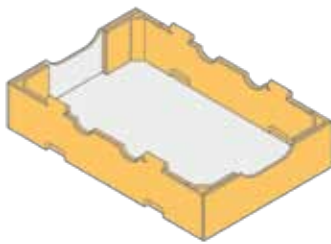

"Common footprint" tray
Vassoio "Common Footprint"
Steige Typ "Common Footprint"
Bandeja "Common Footprint"

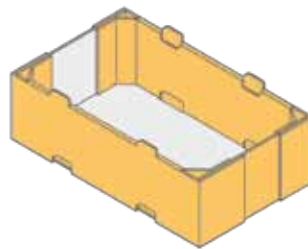

"Citrus" and "P84" tray
Vassoio "citrus" e P84
Steige Typ "Citrus" und P84
Bandeja "citrus" y P84

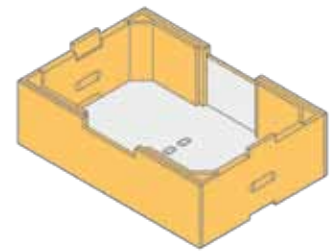

Standard "citrus" tray
Vassoio "citrus" standard
Standardsteige Typ "Citrus"
Bandeja "citrus" estándar

PLAFORM + CITRUS

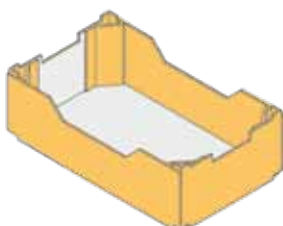

Plaform "citrus" standard
Vassoio "citrus" e P84
Steige Typ "Citrus" und P84
Bandeja "citrus" y P84

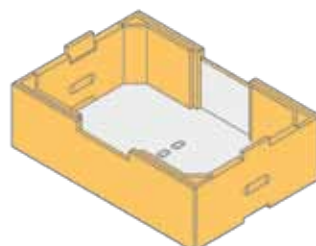

"Citrus" tray with short side fold over
Vassoio tipo "citrus" raddoppio lato corto
Standardsteige Typ "Citrus"
Bandeja "citrus" estándar

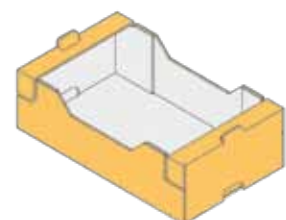

Standard top-flap tray
Vassoio standard con tettuccio
Standardsteige mit Decke
Bandeja estándar con tapa

Optionals

Opzionali

Optional

Opcionales



Additional glue gun for short side doubling
 Pistola aggiuntiva per raddoppio testate
 Zusätzliche Pistole für verdoppelte Kopfseiten
 Pistola adicional para pared doble de las partes superiores



CITRUS tray hopper
 Tramoggia per vassoio CITRUS
 Trichter für Steige CITRUS
 Tolva para bandeja CITRUS



Long and short side doubling
 Raddoppi testate e fiancate
 Verdoppelte Kopfseiten und Seitenwände
 Paredes dobles en las partes superiores y en los laterales



Glue can be applied lengthwise or sidewise, additional glue guns for lengthwise glue application
 Possibilità di applicare la colla longitudinalmente o trasversalmente, pistole colla aggiuntive per colla longitudinale
 Leimauftragen in Längs- und Querrichtung möglich, zusätzliche Pistole zum Leimauftragen in Längsrichtung
 Posibilidad de aplicar la cola longitudinalmente o transversalmente, pistolas de cola adicionales para cola longitudinal



Mechanical lifters
 Alzatori meccanici
 Mechanische Hebevorrichtungen
 Elevadores mecánicos



Air compressor
 Compressore
 Druckvorrichtung
 Compresor

Technical specifications

Dati tecnici

Technische Daten

Datos técnicos

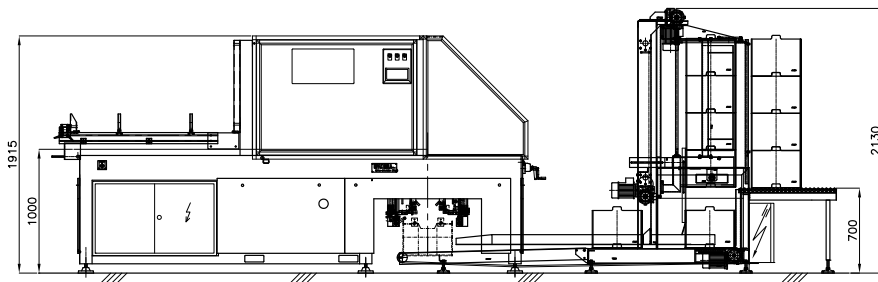

TF12 Evoluzione

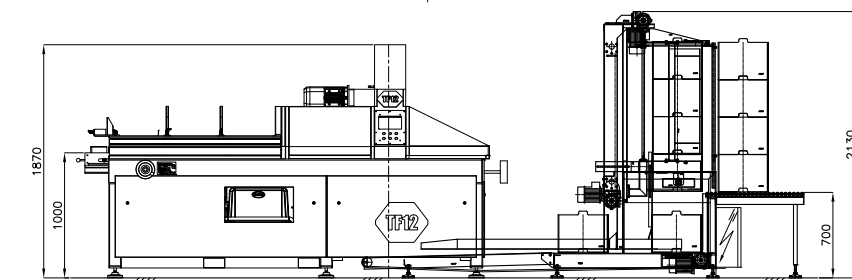
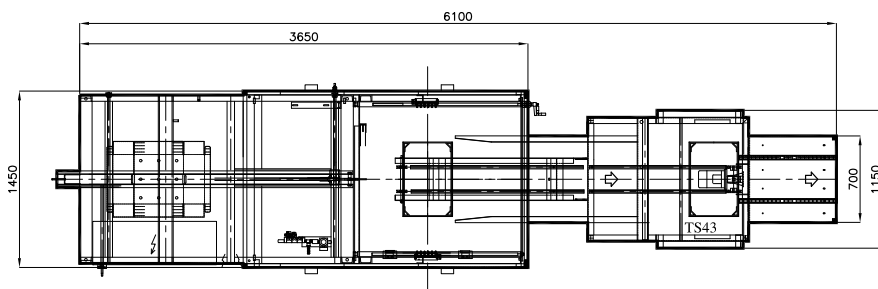

TF12 Compact

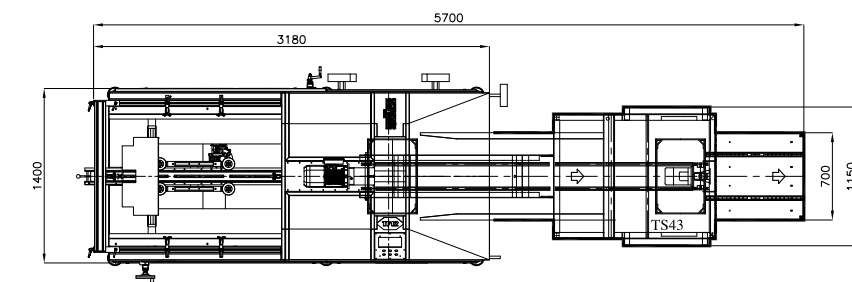

Max tray output	Installed power	Compressed air consumption	Total weight
40 pcs/min	6,5 kW	30 nl/cycle	1400 kg

A range of tailor-made customer services



EN After-sales service guaranteed all over the world

IT Servizio post-vendita e assistenza garantita in tutto il mondo

DE Garantierter Kundendienst in der ganzen Welt

ES Servicio posventa y asistencia garantizada en todo el mundo



Sacmi Packaging S.p.A. Via Brodolini, 10/A - 40026 Imola (BO) Italy
Tel. +39 0542 649 811 - Fax. +39 0542 640 783
E-mail: inform@sacmipackaging.it
www.sacmi.com